

**NEW**

## High-Power 915 nm Multimode Laser

Chip on submount / F package

940, 975nm Available



### Product Specifications at 25°C

Type	OE915G4 Series		
Model No.	915042412		
Operating light output	Po	W	15
Center wavelength	$\lambda_c$	nm	915
Emitter aperture width	Wa	um	100
Cavity Length	L	mm	6
Threshold current	Ith	A	1.2
Slope efficiency	$\eta_s$	W/A	1.0
Operating current	Iop	A	18
Operating voltage	Vop	V	1.8
Spectral width	$\Delta\lambda$	nm	3
Spectral temperature shift	$d\lambda/dT$	nm/K	0.3
Far-field parallel FWHM	$\theta_{//}$	deg.	10
Far-field perpendicular FWHM	$\theta_{\perp}$	deg.	26
Polarization			TE

### Absolute Maximum Ratings

			min	max		
Forward current	I <sub>max</sub>	A	-	20.0	OE915G4	100u aperture
Reverse voltage	V <sub>rmax</sub>	V	-	2.0		
Operating temperature	T <sub>op</sub>	°C	-20	50	non condensing	
Process temperature	T <sub>pr</sub>	°C	-	250	5s, Chip on submount	
ESD		V	-	500	Human Body Model	

# OPTOENERGY

## Typical Characteristics

L-I / FFP

915042412

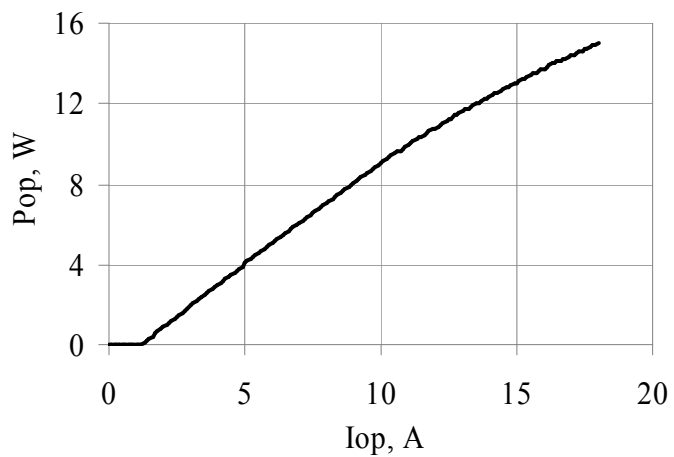

FFP@15W, 25C

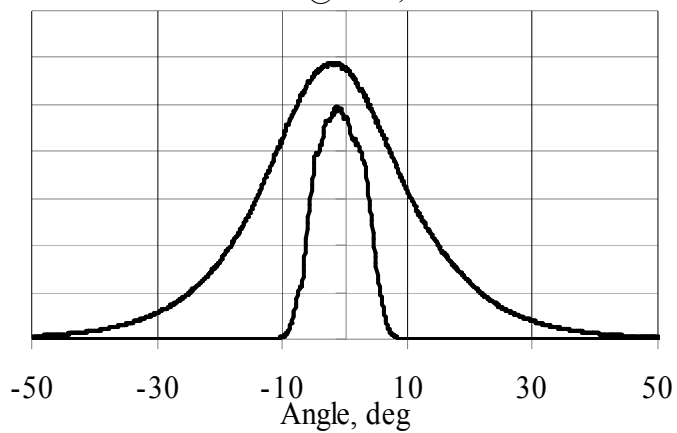

# OPTOENERGY

## Package COS

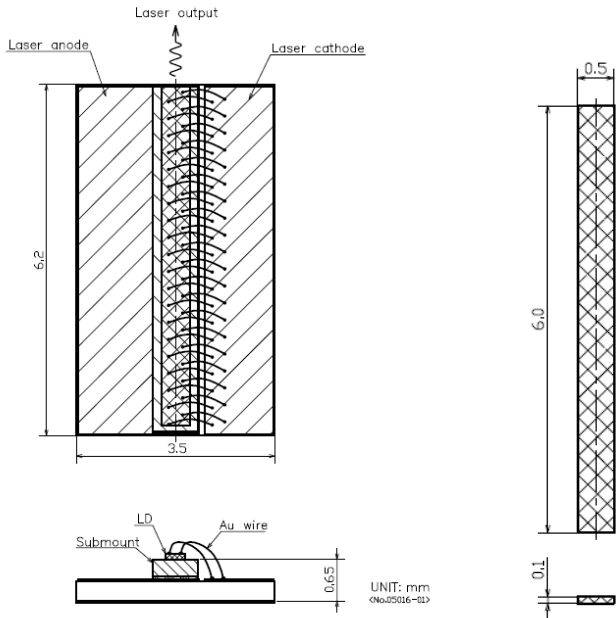

## F-package

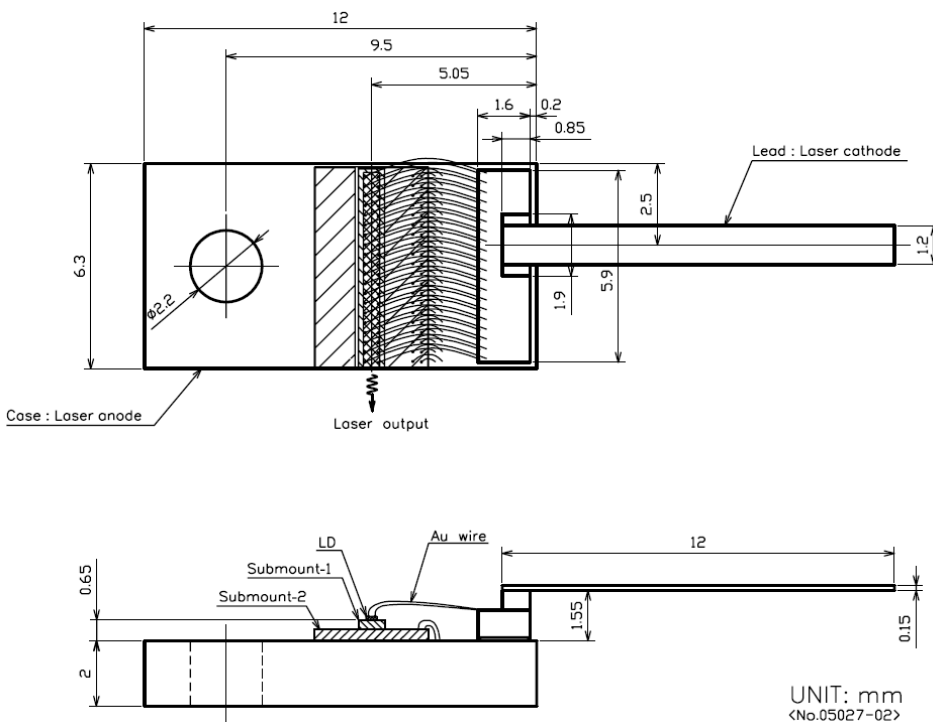

## Caution

This laser emits invisible radiation which may be harmful to the eyes. Avoid direct or reflected light from this device. Because of the small size of these devices, each of the labels is attached to the individual shipping container.